

## GarGraves Uncoupler - Unloader

The controller may be used free standing or securing with screws provided  
**Caution:** Do not apply power to the uncoupler magnet for more than a few seconds at a time to prevent overheating of the magnet. *The Lionel barrel car or Twin Bin dump car may be operated on the left end of this section as shown. If placed with a truck on each end, damage to the controller and/or the car could occur.*

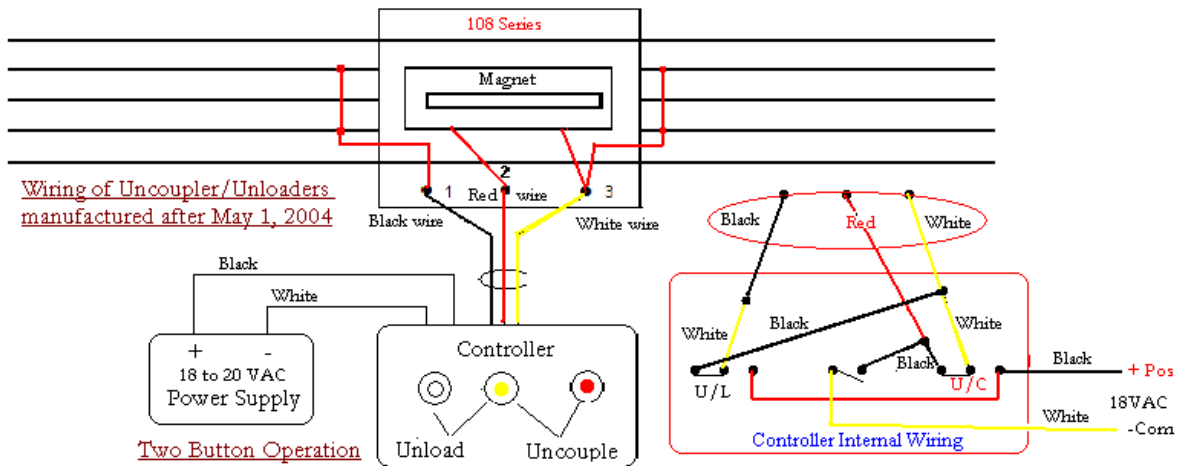

**NOTE: YELLOW BUTTON MUST ALSO BE PUSHED ALONG WITH EITHER  
 Uncouple or Unload Button to Operate**

## GarGraves Uncoupler - Unloader

The controller may be used free standing or secured with screws provided  
**Caution:** Do not apply power to the uncoupler magnet for more than a few seconds at a time to prevent overheating of the magnet. *The Lionel barrel car or Twin Bin dump car may be operated on the left end of this section as shown. If placed with a truck on each end, damage to the controller and/or the car could occur.*

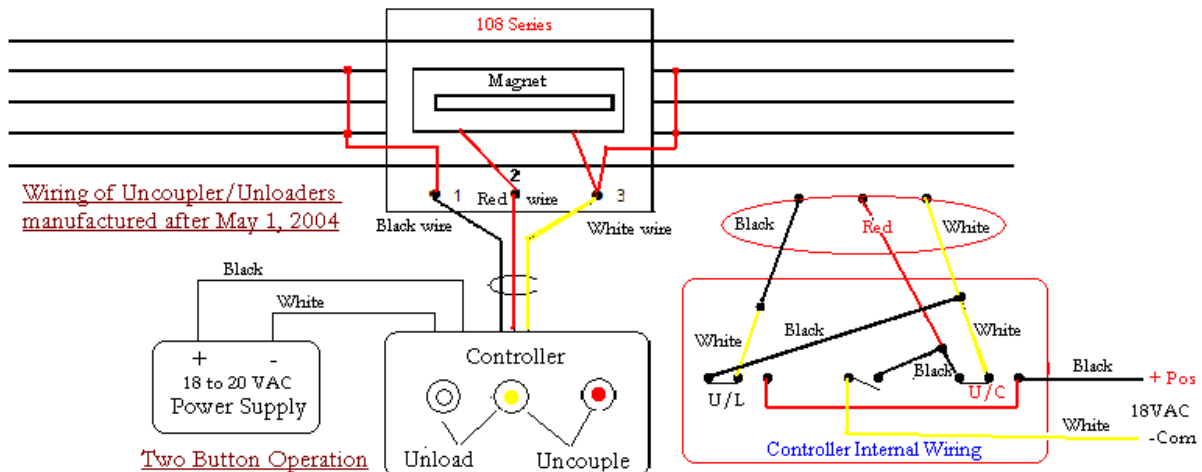

**NOTE: YELLOW BUTTON MUST ALSO BE PUSHED ALONG WITH EITHER  
 Uncouple or Unload Button to Operate**